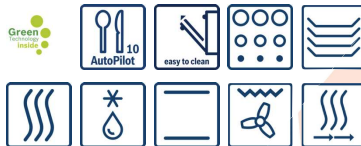

Serie | 8 Ovens
Oven
HBG675BS1, Stainless steel

The built-in oven: you get perfect baking and roasting results.

- **4D Hot Air:** even heat distribution for perfect results – on any level.
- **AutoPilot 10:** every dish is a perfect success thanks to 10 pre-set automatic programmes.
- **TFT display control:** easy-to-use thanks to the control ring with full text and symbols.
- **Pyrolytic self-cleaning:** no cleaning effort thanks to automatic self-cleaning. Appliances with rails, the rails are also pyrolytic proof.
- **Energy efficiency class A+:** Best baking results with lower energy consumption.

Technical Data

Color / Material Front :	Stainless steel
Built-in / Free-standing :	Built-in
Integrated Cleaning system :	Pyrolytic
Required niche size for installation (HxWxD) :	585-595 x 560-568 x 550
Dimensions of the product (mm) :	595 x 594 x 548
Dimensions of the packed product (HxWxD) (mm) :	670 x 680 x 670
Control Panel Material :	Stainless steel
Door Material :	Glass
Net weight (kg) :	38.0
Usable volume of cavity (l) :	71
Cooking method :	, 4D hot air, Bottom heat, Conventional heat, Defrost, Full width grill, Half width grill, Hot Air-Eco, Hot air grilling, low temperature cooking, Pizza setting, pre-heating, warming
First cavity material :	Enamelled
Temperature control :	electronic
Number of interior lights :	1
Approval certificates :	CE, VDE
Length electrical supply cord (cm) :	120
Interior Lights - cavity 1 :	1
Pull-out system :	Accessory
Clock function :	Alarm, Off, On
Included accessories cavity 1 :	1 x enamel baking tray, 1 x combination grid, 1 x universal pan
Broil Element Wattages cavity 1 (W) :	2800
Convection Element Wattages cavity 1 (W) :	2200
Energy efficiency class (2010/30/EC) :	A+
Energy consumption per cycle conventional (2010/30/EC) :	0.87
Energy consumption per cycle forced air convection (2010/30/EC) :	0.69
Energy efficiency index (2010/30/EC) :	81.2
Electrical connection rating (W) :	3600
Current (A) :	16
Voltage (V) :	220-240
Frequency (Hz) :	60; 50
Plug type :	Gardy plug w/ earthing
Color / Material Front :	Stainless steel
Energy input :	Electric
Approval certificates :	CE, VDE
Required cutout/niche size for installation (in) :	x x
Dimensions of the packed product (in) :	26.37 x 26.37 x 26.77
Net weight (lbs) :	84
Gross weight (lbs) :	89
Length electrical supply cord (cm) :	120
Net weight (kg) :	38.0
Gross weight (kg) :	40.0

Serie | 8 Ovens**Oven****HBG675BS1, Stainless steel**

The built-in oven: you get perfect baking and roasting results.

Type of oven / heating system:

- Oven with 13 heating methods: 4D hotair, Hotair Eco,, Conventional heat, Conventional heat ECO, Hot air grilling, Full width grill, Half width grill, Pizza setting, Bottom heat, Low temperature cooking, Defrost, Preheating, Hold warm
- Temperature range 30 °C - 300 °C
- Cavity volume: 71 l

Design:

- Rotary swivel knobs
- Cavity inner surface: Enamel anthracite

Cleaning:

- Pyrolytic self-cleaning function
- Pyrolytic proof trayholder and baking tray
- Full glass inner door

Comfort:

- 2,5"-TFT-color and text display with touch-control buttons
- Temperature proposal
Actual temperature display
heating-up control
AutoPilot
Sabbath setting
- Bottom-hinge opening, Oven door with SoftClose, soft opening
- Supporting systems: Programs
- Number of automatic programmes: 10 PC
- Electronic clock
- Rapid heating-up
- Halogen interior lighting, Switch for oven illumination
- Integral cooling fan
- Stainless-steel fan
- Info button
- Bar handle

Hook-in racks / rails

- Cavity with shelf support rails, Telescopic slide-out Accessory

Accessory:

- 1 x enamel baking tray, 1 x combination grid, 1 x universal pan

Environment and Safety:

- door lock electronical
- Child lock
- Automatic switch off
- Residual heat indicator
- Start/Stop button
- Door contact switch

Technical Info:

- Length of mains cable: 120 cm
- Total connected load electric: 3.6 KW
- Appliance dimension (hxwxh): 595 mm x 594 mm x 548 mm
- Niche dimension (hxwxh): 585 mm - 595 mm x 560 mm - 568 mm x 550 mm
- "Please reference the built-in dimensions provided in the installation drawing"
- very low door temperature
- Energy efficiency rating (acc. EU Nr. 65/2014): A+ (at a range of energy efficiency classes from A+++ to D)
Energy consumption per cycle in conventional mode: 0.87 kwh
Energy consumption per cycle in fan-forced convection mode: 0.69 kwh
Number of cavities: 1
Heat source: electrical
Cavity volume: 71 l

Serie | 8 Ovens

Oven
HBG675BS1, Stainless steel

Installation with a hob.

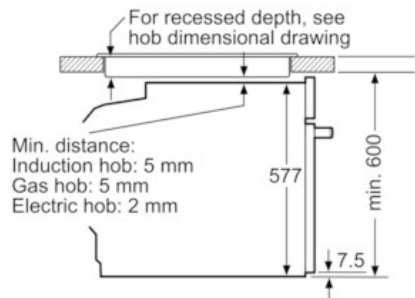

measurements in mm

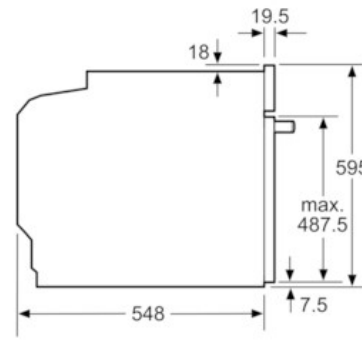

measurements in mm

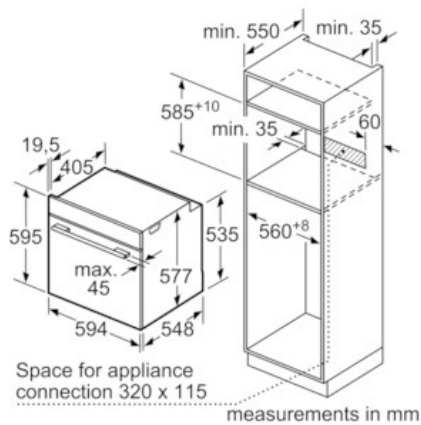

measurements in mm

If the appliance will be installed underneath a hob, the following worktop thicknesses (including substructure if necessary) must be taken into account.

Hob type	min. worktop thickness	
	fitted	flush
Induction hob	37 mm	38 mm
Full surface Induction hob	47 mm	48 mm
Gas hob	30 mm	38 mm
Electric hob	27 mm	30 mm

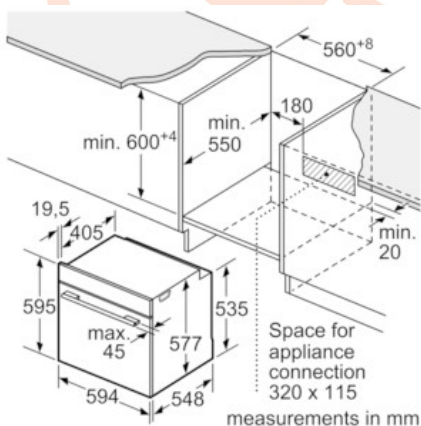

measurements in mm